

Low Pressure Second Stage Regulators - Standard Settings

LV5503B Series

Application

Designed to reduce first stage pressure of 5 to 20 PSIG down to burner pressure, normally 11" w.c. Ideal for larger commercial and industrial applications, multiple cylinder installations and large domestic systems.



LV5503B Series

Features

- Incorporates integral relief valve.
- With 15 PSIG inlet pressure, regulator is designed to not pass more than 2 PSIG with the seat disc removed.
- Replaceable valve orifice and valve seat disc.
- Straight line valve closure saves wear on seat disc and orifice.
- Built in pressure tap has plugged 1/8" F.NPT outlet. Plug can be removed with a 3/16" hex allen wrench.
- Large bonnet vent profile minimizes vent freeze over when properly installed.
- Extra long lever arm for uniform delivery pressure.
- Large diaphragm is extra sensitive to pressure changes.

Materials

Body (LV5503B Series)	Die Cast Aluminum
Bonnet (LV5503B Series)	Die Cast Aluminum
Nozzle Orifice	Brass
Spring	Steel
Valve Seat Disc	Resilient Rubber
Diaphragm	Integrated Fabric and Synthetic Rubber

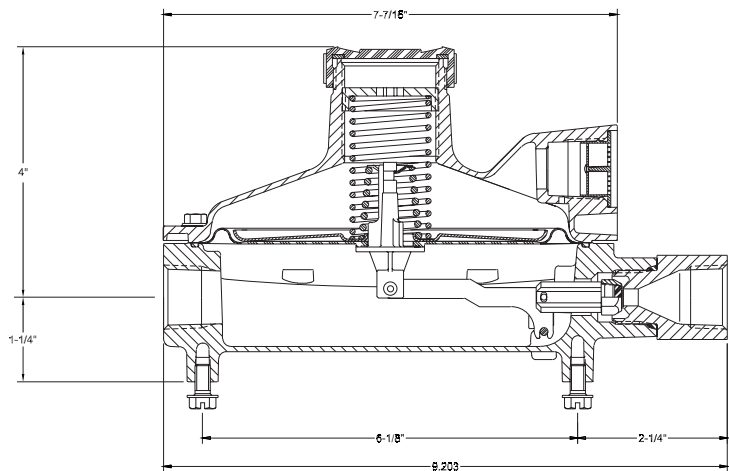

LV5503B4, LV5503B6

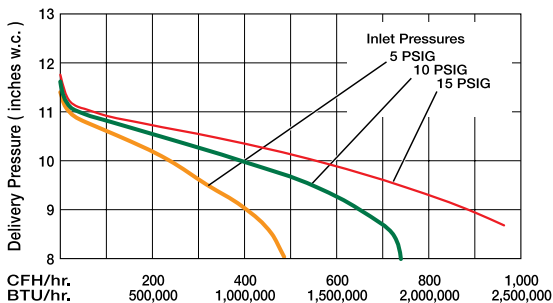

LV5503B8

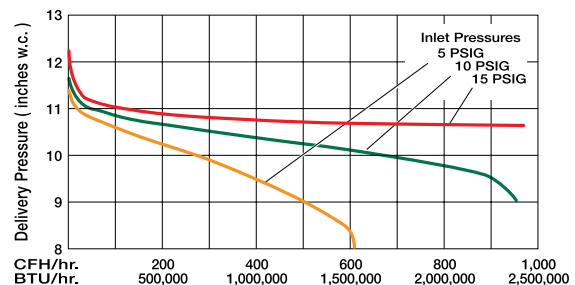

Ordering Information

Part Number	Inlet Connection	Outlet Connection	Orifice Size	Factory Delivery Pressure	Adjustment Range	Bonnet Vent Position	Vapor Capacity BTU/hr. Propane
LV5503B4	1/2" F. NPT	3/4" F. NPT	1/4"	11" w.c. at 10 PSIG Inlet	9" - 13" w.c.	Over Inlet	1,600,000
LV5503B6	3/4" F. NPT						
LV5503B8		1" F. NPT	9/32"				2,300,000

Maximum flow is based on 10 PSIG inlet and 9" w.c. delivery pressure.